

► PONTE SOLLEVATORE A 2 COL/ 4T



IEQ1000 / IEQ1001

IEQ1000 Monofase 230V

IEQ1001 Trifase 400V



4.000 kg



400V/3ph/50Hz
230V/1ph/50Hz



2.2KW



790 kg



ZOOM PRODOTTO

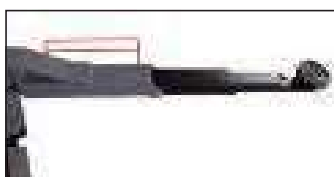

Piano di adeguatezza del suolo : spessore lastra ≥ 200 mm, resistenza del calcestruzzo ≥ 30 N/mm, dislivello massimo di 10 mm.

- Portata: **4 000 kg**
- Estensioni per tamponi: **80 mm**
- Bracci uguali simetrici
- Salita/discesa: **40/60 secondes**
- Sistema de fermata elettromeccanico
- Funzione discesa diretta
- Sistema di sicurezza idraulica in caso di sovraccarico o rottura dal tubo flessibile
- Comando a uomo presente
- Dispositivo di appoggio meccanico ad inserimento automatico per una maggiore durata dei componenti
- Peso: **790 kg**



4.000 kg



400V/3ph/50Hz

230V/1ph/50Hz



2.2KW



790 kg

IL



- > Portata 4 tonellate
- > Bracci simmetrici per la massima comodità di lavoro e ideali per tutti i tipi di veicoli larghi e profilo basso
- > Base per un migliore ancoraggio al suolo
- > Bassa manutenzione

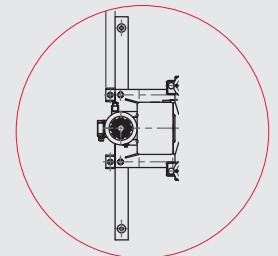
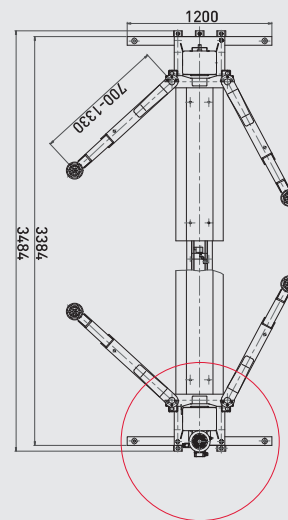
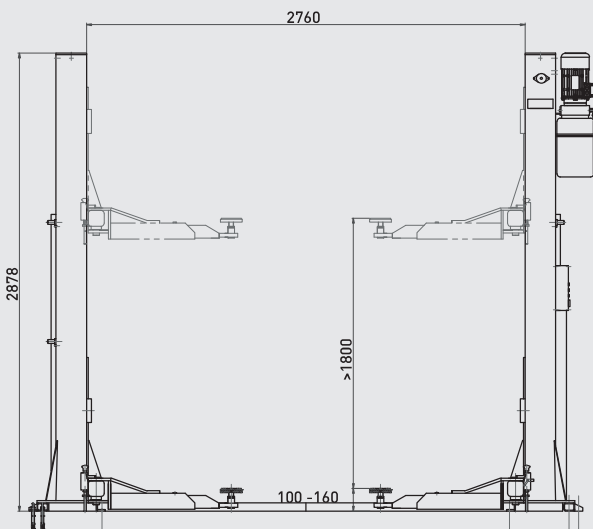

ACCESSORI STANDARD

DH1046
ESTENSIONE - 80 MM

DH1039B
TAMPONI IN GOMMA - Ø 135 MM



DH1046



DH1039

ACCESSORI OPZIONALI

DH1045
ESTENSIONE - 145 MM

B1968 + B1969 + B1962
SET DI BRACCI CORTI -3 SEZIONE - 600 / 1100 MM,
PER SOLLEVAMENTO DEI VEICOLI PIU PICCOLI



DH1045



B1968 - B1969N